

MechTrac 1730/ 2100/ 2500/ 3000

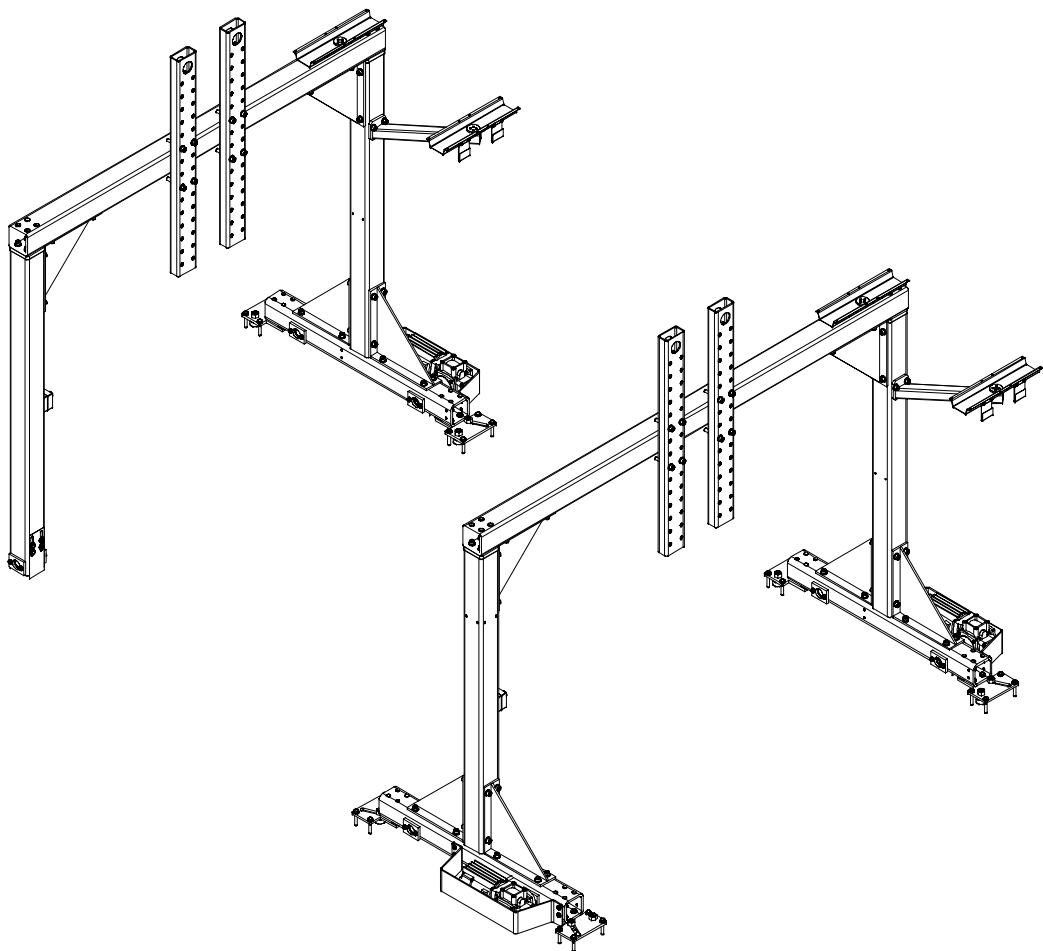

**Bruksanvisning
Brugsanvisning
Bruksanvisning
Käyttöohjeet
Instruction manual
Betriebsanweisung**

**Manuel d'instructions
Gebruiksaanwijzing
Instrucciones de uso
Istruzioni per l'uso
Manual de instruções
Οδηγίες χρήσεως**

SVENSKA	5
DANSK	14
NORSK	23
SUOMI	32
ENGLISH	41
DEUTSCH	50
FRANÇAIS	59
NEDERLANDS	68
ESPAÑOL	77
ITALIANO	86
PORTUGUÊS	95
ΕΛΛΗΝΙΚΑ	104

Rätt till ändring av specifikationer utan avisering förbehålles.
Ret til ændring af specifikationer uden varsel forbeholdes.
Ret til å ændre spesifikasjoner uten varsel forbeholdes.
Oikeudet muutoksiin pidätetään.
Rights reserved to alter specifications without notice.
Änderungen vorbehalten.
Sous réserve de modifications sans avis préalable.
Recht op wijzigingen zonder voorafgaande mededeling voorbehouden.
Reservado el derecho de cambiar las especificaciones sin previo aviso.
Ci riserviamo il diritto di variare le specifiche senza preavviso.
Reservamo-nos o direito de alterar as especificações sem aviso prévio.
Διατηρείται το δικαίωμα τροποποίησης προδιαγραφών Χωρίς προειδοποίηση.

FÖRSÄKRAN OM ÖVERENSSTÄMMELSE

ESAB AB Welding Automation, 695 81 Laxå, Sverige, försäkrar under eget ansvar att svetsutrustning MechTrac 1730/ 2100/ 2500/ 3000 från serienummer 0243 är i överensstämmelse med standard EN 60292 och EN 60204 enligt villkoren i direktiv (89/392/EEG) med tillägg (93/68/EEG).

OVERENSSTEMMELSEERKLÆRING

ESAB AB Welding Automation, S- 695 81 Laxå, Sverige, erklærer på eget ansvar, at svejseudstyr MechTrac 1730/ 2100/ 2500/ 3000 fra serienummer 0243 er i overensstemmelse med standarden EN 60292 og EN 60204 ifølge betingelserne i direktiv (89/392/EØF) med tillæg (93/68/EØF).

FORSIKRING OM SAMSVAR

ESAB AB Welding Automation, S-695 81 Laxå, Sverige, försäkrar på eget ansvar at sveiseutstyr MechTrac 1730/ 2100/ 2500/ 3000 fra serienummer 0243 er i overensstemmelse med standard EN 60292 og EN 60204 i følge vilkårene i direktiv (89/392/EF) med tillegg (93/68/EF).

VAATIMUSTENMUKAISUUSVAKUUTUS

ESAB AB Welding Automation, S-695 81 Laxå, Ruotsi, vakuuttaa omalla vastuullaan, että hitsauslaitteisto MechTrac 1730/ 2100/ 2500/ 3000 alkaen sarjanumerosta 0243 täyttää standardin EN 60292 ja EN 60204 vaatimukset direktiivin (89/392/ETY) ja sen lisäysten (93/68/ETY).

DECLARATION OF CONFORMITY

ESAB AB Welding Automation, S-695 81 Laxå, Sweden, gives its unreserved guarantee that welding equipment MechTrac 1730/ 2100/ 2500/ 3000 from serial number 0243 complies with standard EN 60292 and EN 60204, in accordance with the requirements of directive (89/392/EEC) and addendum (93/68/EEC).

ZULASSUNGSNACHWEIS

ESAB AB Welding Automation, S-695 81 Laxå Schweden, bestätigt hiermit in Eigenverantwortung, daß der Schweißausrüstung MechTrac 1730/ 2100/ 2500/ 3000 ab Seriennummer 0243 dem Standard EN 60292 und EN 60204 gemäß den Bedingungen der Direktive (89/392/EEG) mit Zusatz (93/68/EEG).

CERTIFICAT DE CONFORMITÉ

ESAB AB Welding Automation, S-695 81 Laxå, Suède, certifie que l'équipement de soudage MechTrac 1730/ 2100/ 2500/ 3000 à partir du numéro de série 0243 est conforme à la norme EN 60292 et EN 60204 selon les conditions de la directive (89/392/CEE) avec additif (93/68/CEE).

VERKLARING VAN OVEREENSTEMMING

ESAB AB Welding Automation, S-695 81 Laxå Zweden, verklaart geheel onder eigen verantwoordelijkheid dat lasuitrusting MechTrac 1730/ 2100/ 2500/ 3000 van het serienummer 0243 in overeenstemming is met norm EN 60292 en EN 60204 conform de bepalingen in richtlijn (89/392/EEG) met annex (93/68/EEG).

DECLARACIÓN DE CONFORMIDAD

ESAB AB Welding Automation, S-695 81 Laxå, Suecia, garantiza bajo propia responsabilidad que el equipo de soldadura MechTrac 1730/ 2100/ 2500/ 3000 a partir del número de serie 0243 concuerda con la norma EN 60292 y EN 60204 conforme a la directiva (89/392/CEE) con el suplemento (93/68/CEE).

DICHIARAZIONE DI CONFORMITA

ESAB AB Welding Automation, S-695 81 Laxå Svezia, dichiara sotto la propria responsabilità che una apparecchio per saldatura MechTrac 1730/ 2100/ 2500/ 3000 con numero di serie a partire da 0243 è conforme alla norma EN 60292 e EN 60204 come previsto dalla direttiva (89/392/CEE) e successive integrazioni (93/68/CEE).

DECLARAÇÃO DE CONFORMIDADE

ESAB AB Welding Automation, S-695 81 Laxå Suécia, garante sob responsabilidade própria que a equipamento de soldadura MechTrac 1730/ 2100/ 2500/ 3000 a partir do número de série 0243 está em conformidade com a norma EN 60292 e EN 60204 segundo os requisitos da directiva (89/392/CEE) com o suplemento (93/68/CEE).

ΔΗΛΩΣΗ ΣΥΜΜΟΡΦΩΣΗΣ

Η εταιρεία ESAB AB Welding Automation, S-695 81 Laxå, Σουηδία, δηλώνει ότι τα μηχανήματα Ηλεκτροσυγκόλλησης MechTrac 1730/ 2100/ 2500/ 3000 από τον αριθμό σειράς 0243 και έπειτα, συμμορφώνονται με το πρότυπο EN 60292 και EN 60204 σύμφωνα με τις απαιτήσεις της οδηγίας (89/392/EEG) και του παραρτήματος (93/68/EEG).

Laxå 2003-04-11



Kennet Fahlström
Group Manager Mechanical Design
Automation Products
ESAB AB Welding Automation
695 81 LAXÅ
SWEDEN

Tel: + 46 584 81000

Fax: + 46 584 411721

**Måttskiss Målskitse Målskisse Mittapiirustus Dimension drawing Mass-
bild Cotes d'encombrement Maatschets Croquis acotado Dimensioni
Esboço com dimensões Σχεδιάγραμμα μεγεθών**

Double version

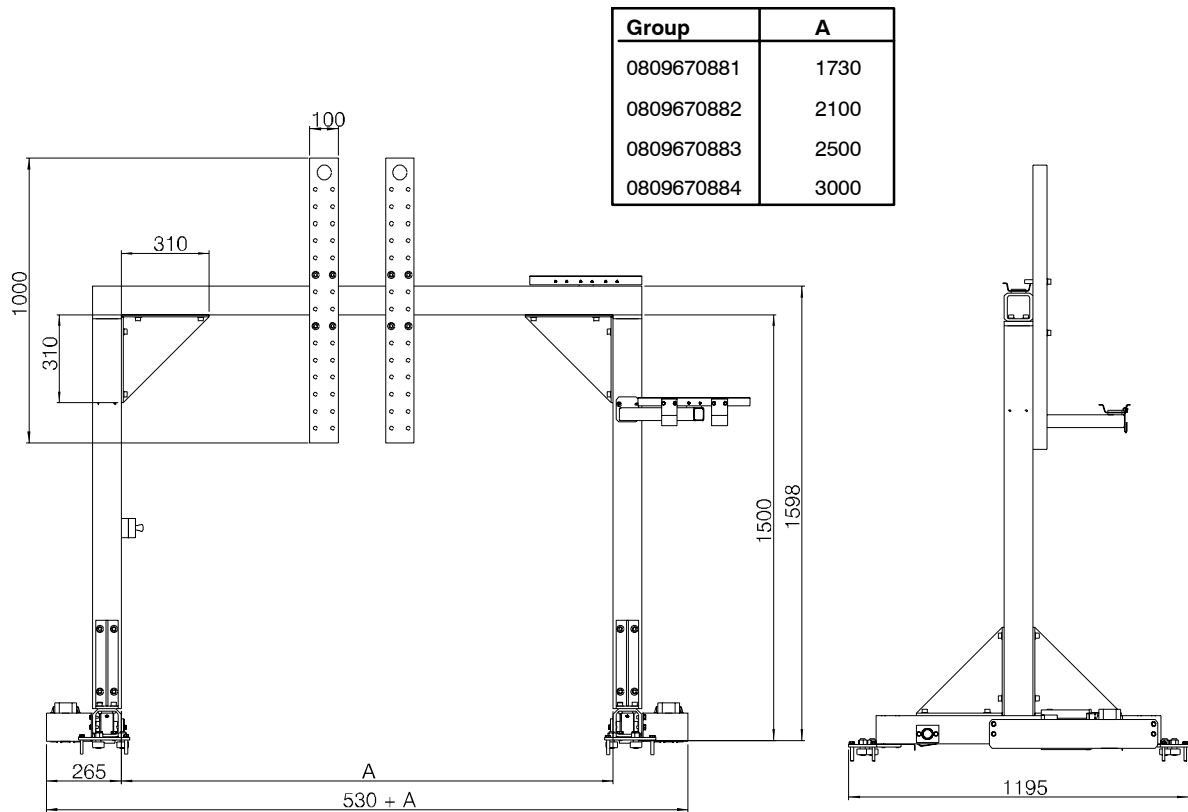

Single version

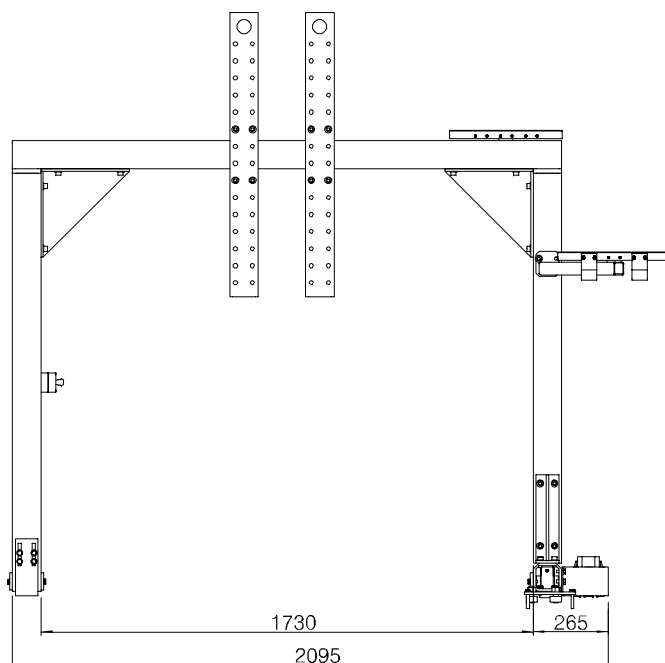

Rail foundation

The rail is bolted with M12 bolts.

Use metal sheets of different thickness to adjust the rail according to dimensions.

Group	A
0809670881	1730
0809670882	2100
0809670883	2500
0809670884	3000

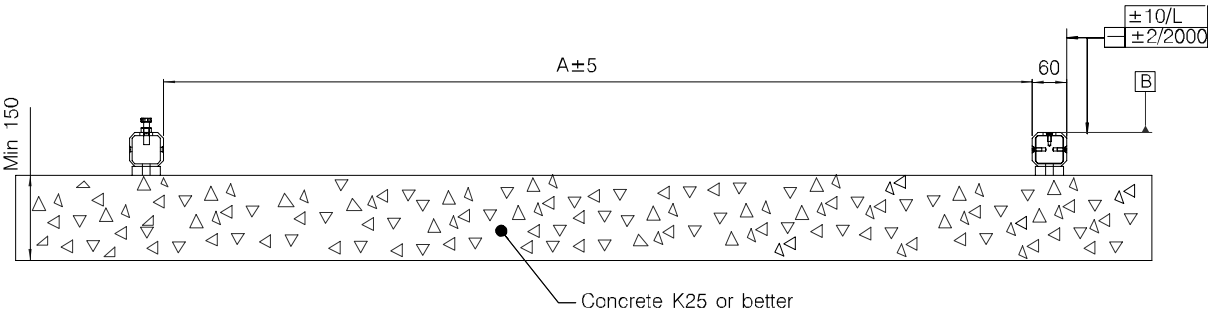

Emergency stop circuit

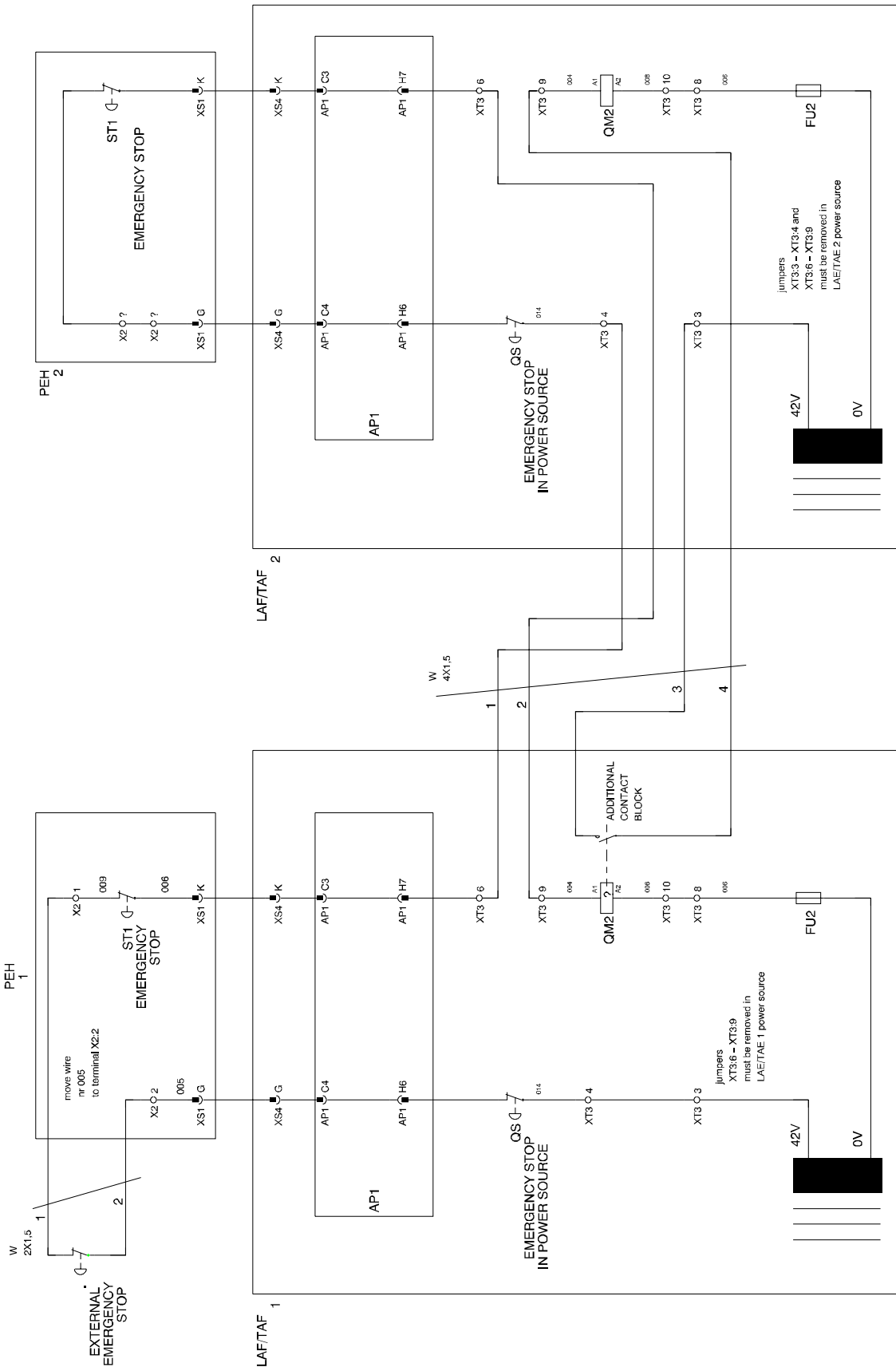

Reservdelsförteckning Reservdelsfortegnelse Reservdelsliste
 Varaosaluettelo Spare parts list Ersatzteilliste Liste de pièces détachées
 Reserveonderdelenlijst Lista de repuestos Elenco ricambi Lista de peças
 sobressalentes Πίνακας ανταλλακτικών μερών

MechTrac 1730/ 2100/ 2500/ 3000

Edition 2003-04-11

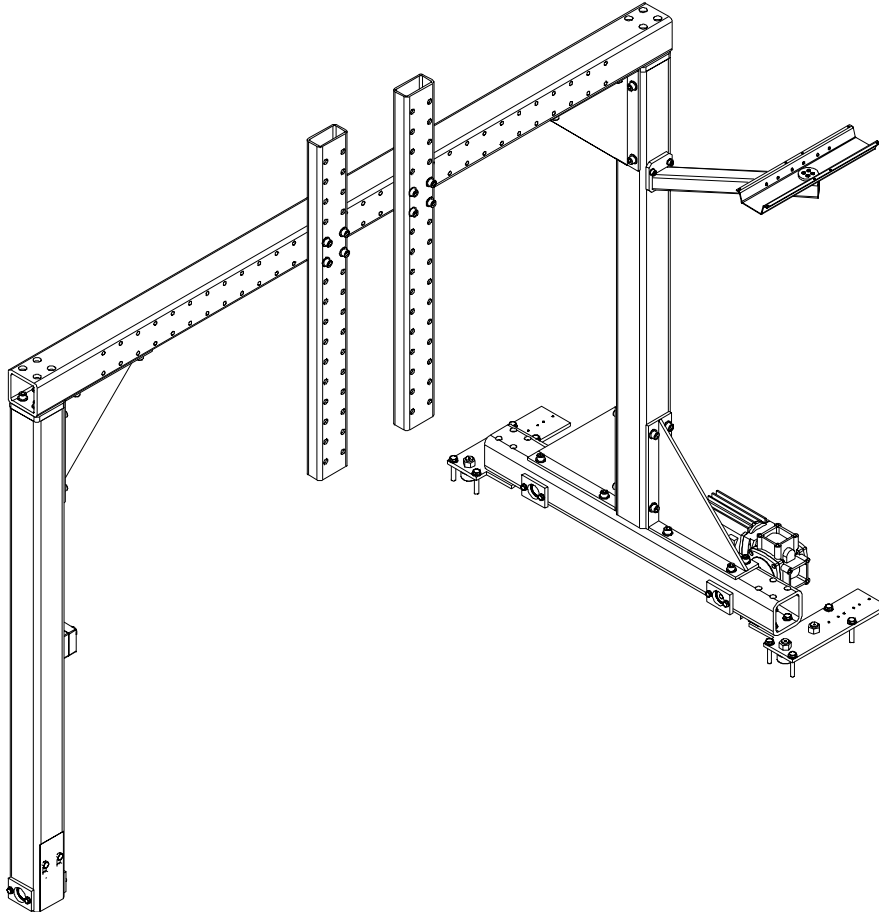

Ordering no.	Denomination	Notes
0809 670 880	Gantry	MechTrac 1730 (Single)
0809 670 881	Gantry	MechTrac 1730 (double)
0809 670 882	Gantry	MechTrac 2100
0809 670 883	Gantry	MechTrac 2500
0809 670 884	Gantry	MechTrac 3000
0806 707 880	Rail complete	
0806 707 881	Rail complete	

Item no.	Qty	Ordering no.	Denomination	Notes
		0809670880	Gantry	MechTrac 1730 (single)
1	1	0809662001	Beam	
2	1	0809667881	Drive kit, right	
3	1	0809668880	Leg	
5	2	0806474880	Support	
6	1	0806738225	Emergency stop box	
7	2	0449320001	Attachment	
8	2	0806471001	Bracket	
9	1	0334522880	Box holder	
10	2	0334187001	Box girder beam	
11	8	0219504405	Cup spring	
12	2	0153321001	Disc	
13	2	0153322001	Disc	

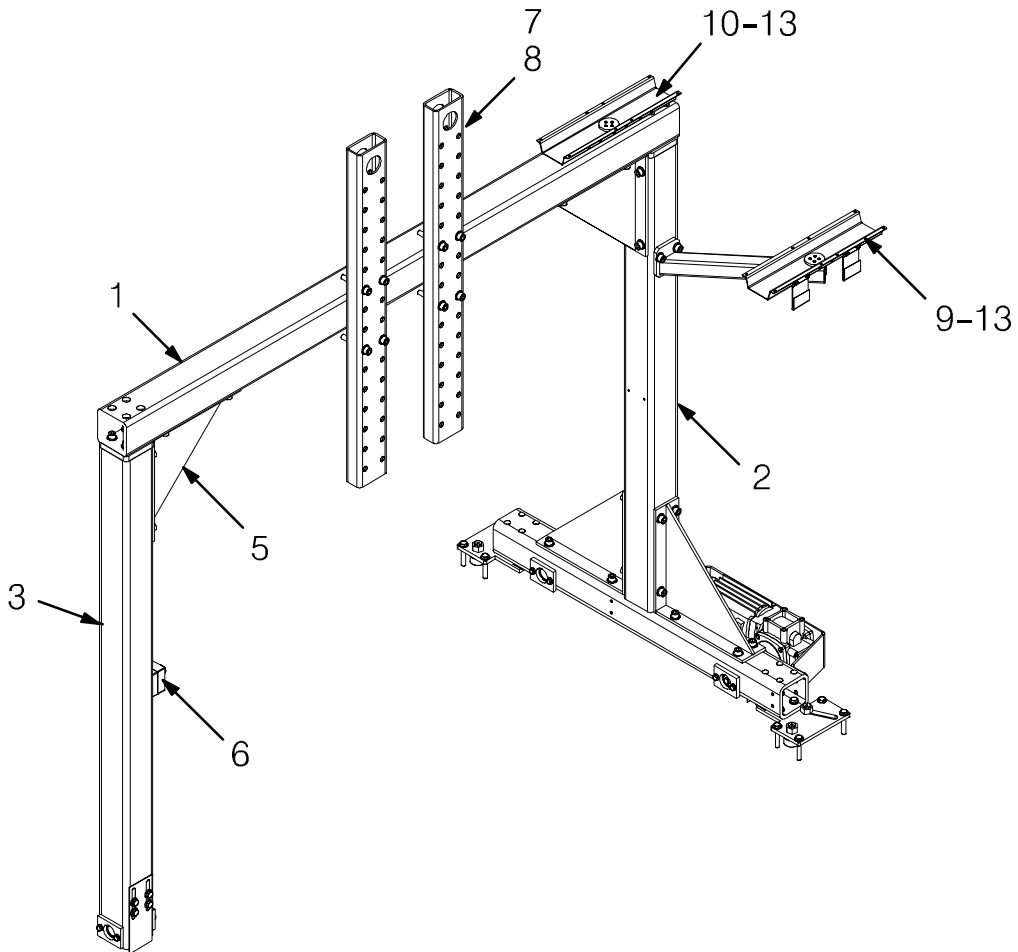

Item no.	Qty	Ordering no.	Denomination	Notes
		0809670882	Gantry	MechTrac 2100 (double)
2	1	0809667881	Drive kit, right	
4	1	0809667880	Drive kit, left	
5	2	0806474880	Support	
6	1	0806738225	Emergency stop box	
7	2	0449320001	Attachment	
8	2	0806471001	Bracket	
9	1	0334522880	Box holder	
10	2	0334187001	Box girder beam	
11	8	0219504405	Cup spring	
12	2	0153321001	Disc	
13	2	0153322001	Disc	
24	1	0809662002	Beam	

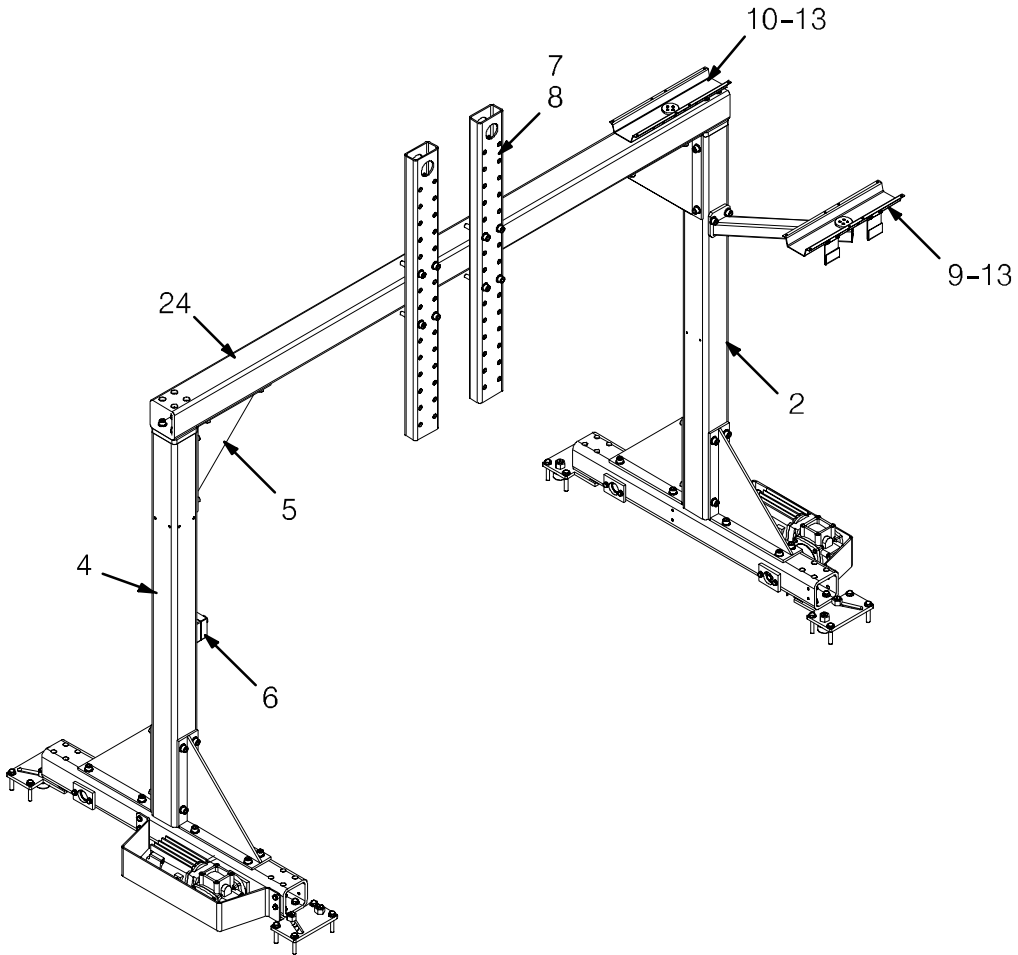

Item no.	Qty	Ordering no.	Denomination	Notes
		0809670884	Gantry	MechTrac 3000 (double)
2	1	0809667881	Drive kit, right	
4	1	0809667880	Drive kit, left	
5	2	0806474880	Support	
6	1	0806738225	Emergency stop box	
7	2	0449320001	Attachment	
8	2	0806471001	Bracket	
9	1	0334522880	Box holder	
10	2	0334187001	Box girder beam	
11	8	0219504405	Cup spring	
12	2	0153321001	Disc	
13	2	0153322001	Disc	
26	1	0809662004	Beam	

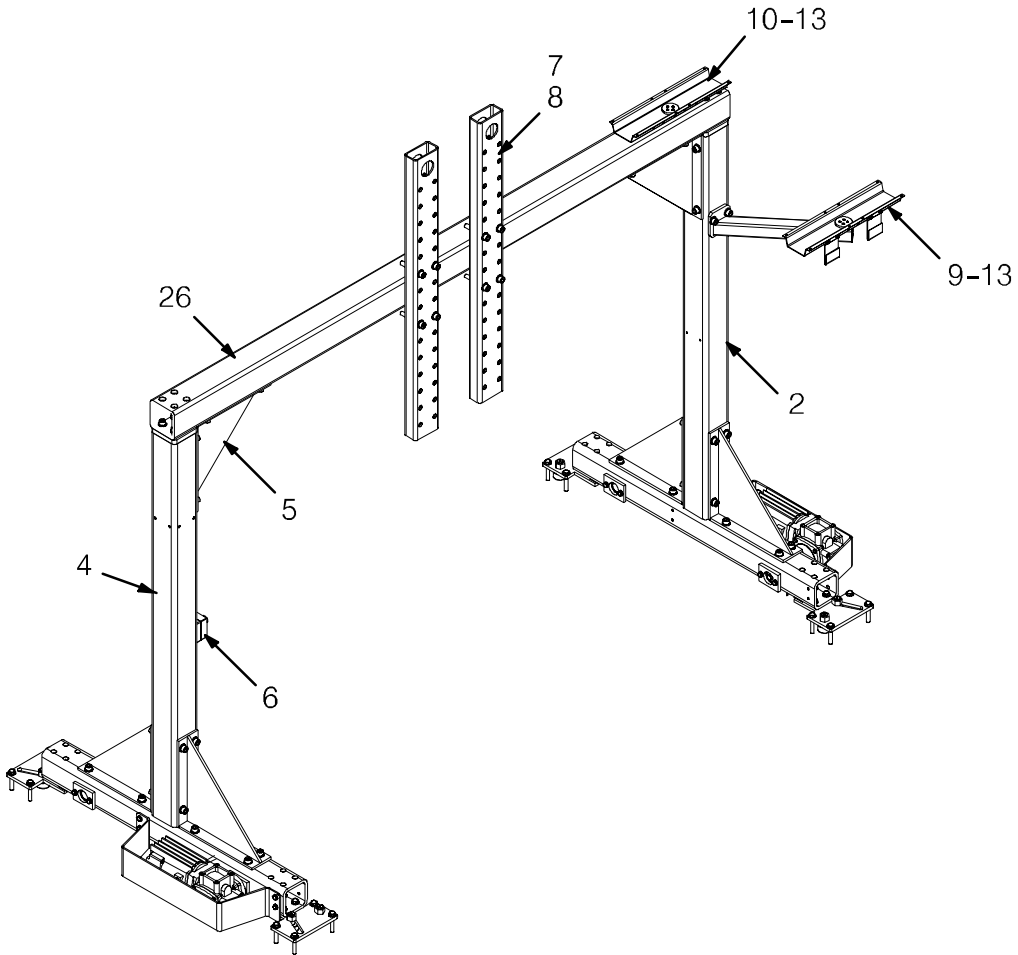

Item no.	Qty	Ordering no.	Denomination	Notes
		0809667880	Drive kit, left	
1	1	0806484880	Left leg	
2	1	0806477001	Leg	
3	2	0806474880	Support	
4	2	0809666002	Holder	
5	1	0806479001	Drive shaft	
6	1	0806479002	Drive shaft	
7	4	0806480001	Ball-bearing	
8	2	0806485001	Wheel	
9	4	0806472001	Bracket	
10	4	0806475001	Roller	
12	2	0211103007	Roll pin	d 8x36
18	1	0147018902	Motor with gear	A6 VEC
19	1	0806490038	Threaded rod	
20	2	0806476001	Scraper, angled	
23	1	0456490884	Cable	7 m
25	1	0449319001	Protection	
28	1	0161337058	Box	

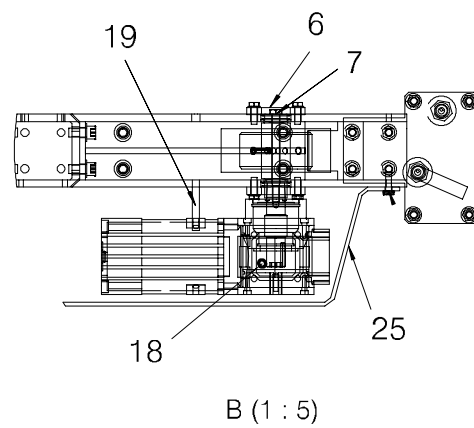
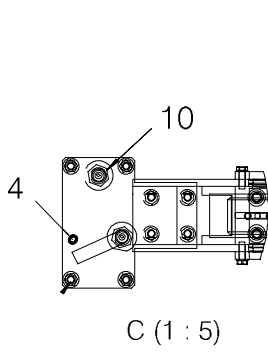
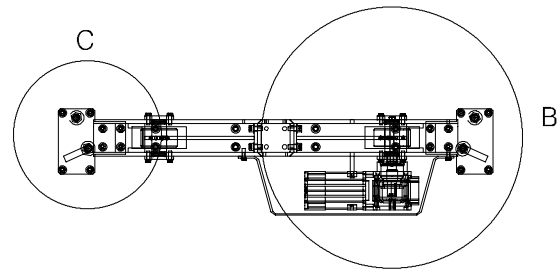
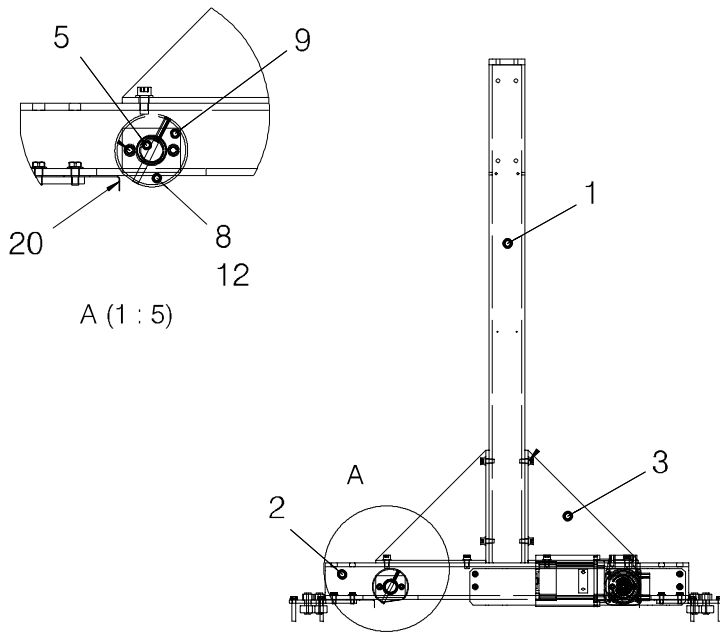

Item no.	Qty	Ordering no.	Denomination	Notes
		0809667881	Drive kit, right	
1	1	0806484880	Left leg	
2	1	0806477001	Leg	
3	2	0806474880	Support	
4	2	0809666002	Holder	
5	1	0806479001	Drive shaft	
6	1	0806479002	Drive shaft	
7	4	0806480001	Ball-bearing	
8	2	0806485001	Wheel	
9	4	0806472001	Bracket	
10	4	0806475001	Roller	
12	2	0211103007	Roll pin	d 8x36
19	1	0806490038	Threaded rod	
20	2	0806476001	Scraper, angled	
23	1	0456490884	Cable	7 m
25	1	0449319001	Protection	
28	1	0161337058	Box	
29	1	0147018892	Motor with gear	A6 VEC

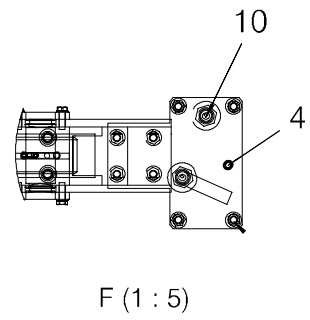
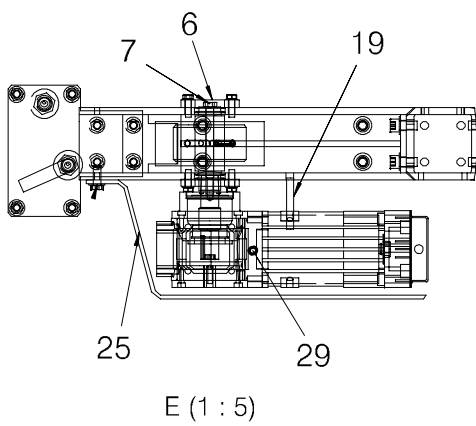
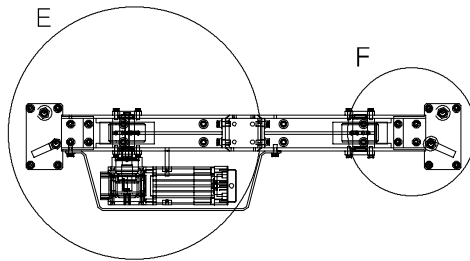
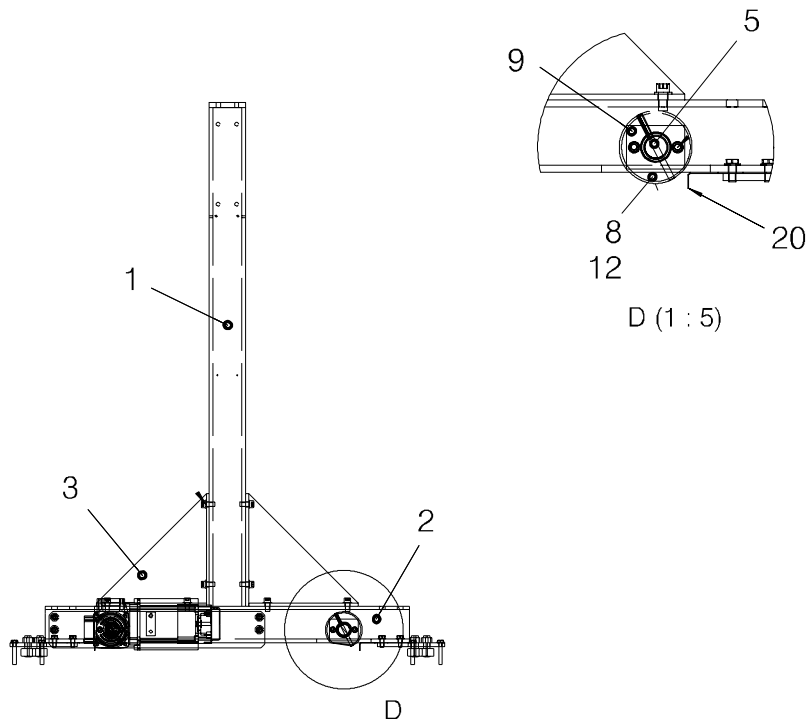

Item no.	Qty	Ordering no.	Denomination	Notes
		0809668880	Leg	
1	1	0806482880	Right leg	
2	1	0806485001	Wheel	
3	1	0806479001	Shaft	
4	2	0806472001	Bracket	
5	2	0806480001	Ball-bearing	
6	2	0806478001	Scraper	
7	1	0211103007	Roll pin	d 8x36

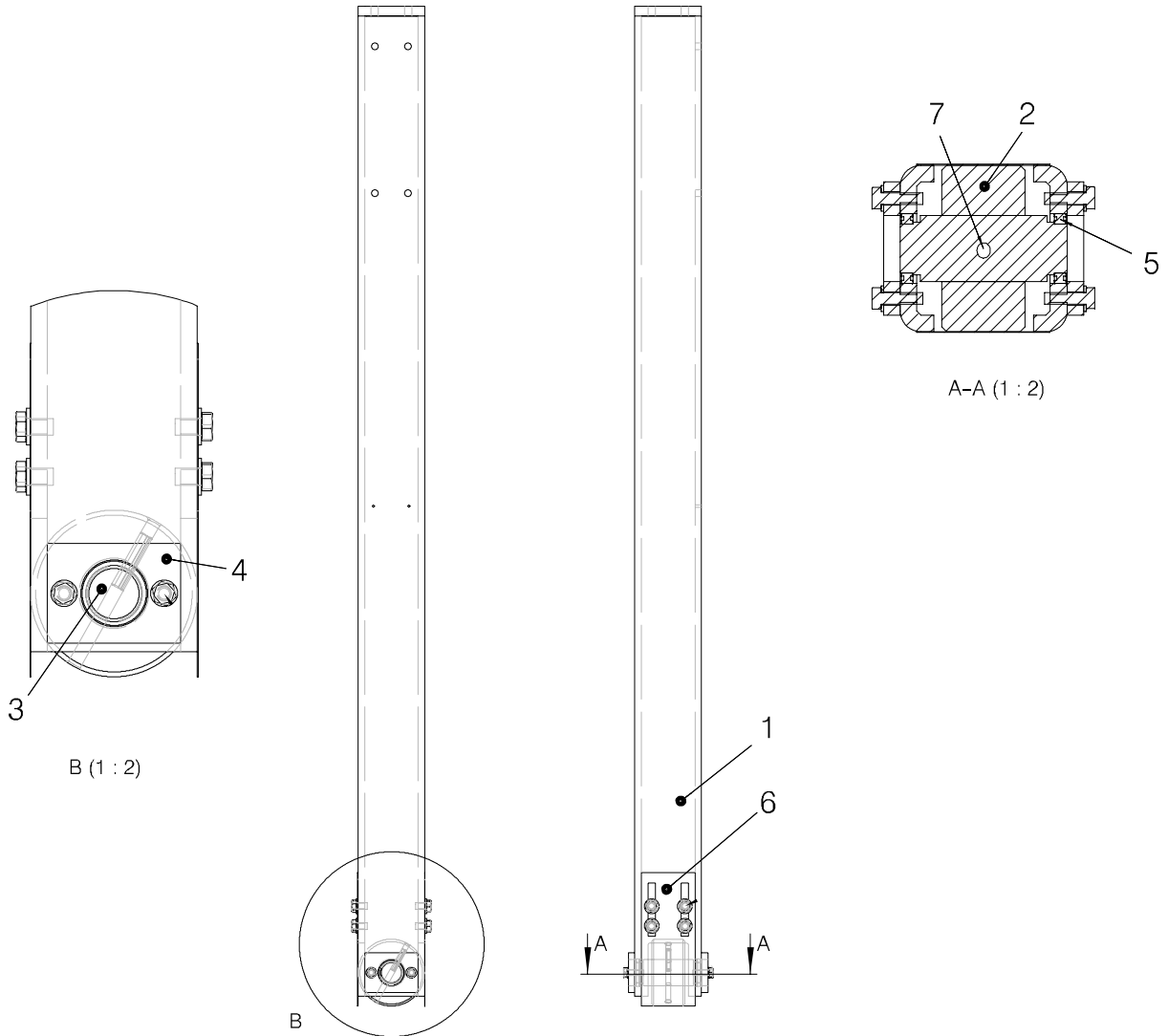

Item no.	Qty	Ordering no.	Denomination	Notes
		0806 707 880	Rail (Basic)	
1	2	0806 700 001	Rail	
4	8	0806 701 001	Base plate	
5	2	0212 601 110	Nut	M10
6	2	0212 101 608	Screw	M10x40
		0806 707 881	Rail (Extension)	
1	2	0806 700 001	Rail	
2	2	0806 703 001	Inner plate	
3	12	0190 684 638	Screw	M16x90
4	8	0806 701 001	Base plate	

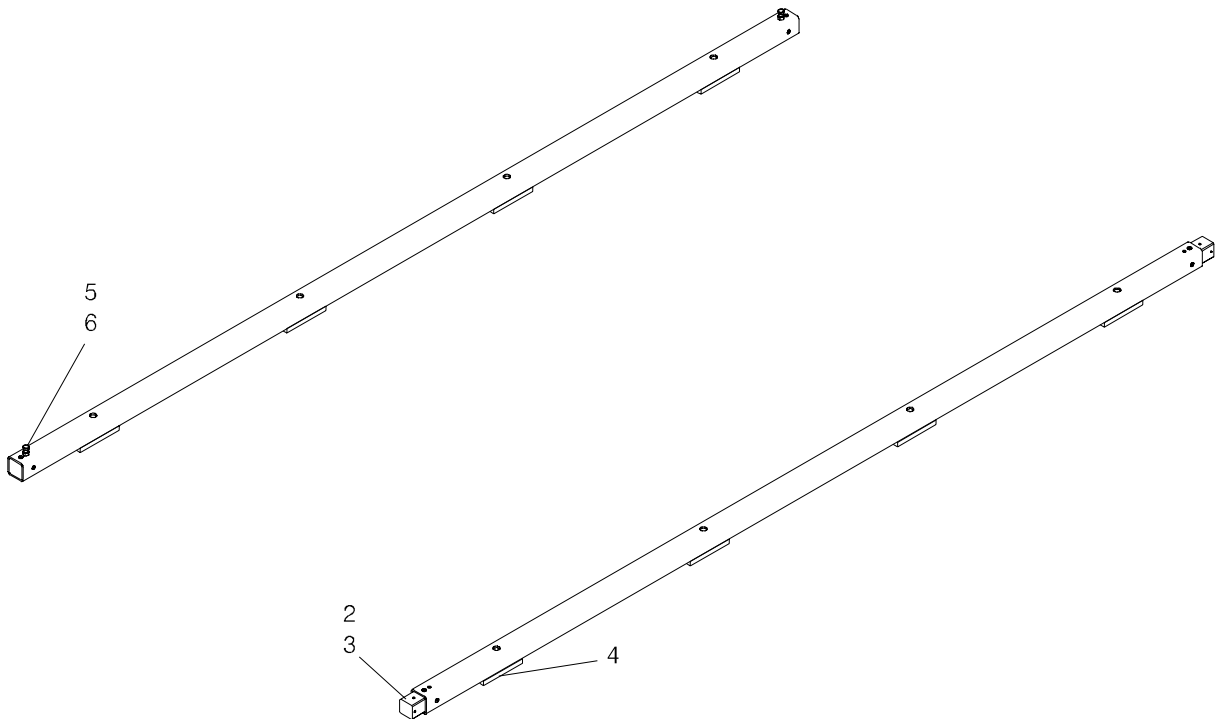

ESAB subsidiaries and representative offices

Europe

AUSTRIA

ESAB Ges.m.b.H
Vienna-Liesing
Tel: +43 1 888 25 11
Fax: +43 1 888 25 11 85

BELGIUM

S.A. ESAB N.V.
Brussels
Tel: +32 2 745 11 00
Fax: +32 2 726 80 05

THE CZECH REPUBLIC

ESAB VAMBERK s.r.o.
Prague
Tel: +420 2 819 40 885
Fax: +420 2 819 40 120

DENMARK

Aktieselskabet ESAB
Copenhagen-Valby
Tel: +45 36 30 01 11
Fax: +45 36 30 40 03

FINLAND

ESAB Oy
Helsinki
Tel: +358 9 547 761
Fax: +358 9 547 77 71

FRANCE

ESAB France S.A.
Cergy Pontoise
Tel: +33 1 30 75 55 00
Fax: +33 1 30 75 55 24

GERMANY

ESAB GmbH
Solingen
Tel: +49 212 298 0
Fax: +49 212 298 204

GREAT BRITAIN

ESAB Group (UK) Ltd
Waltham Cross
Tel: +44 1992 76 85 15
Fax: +44 1992 71 58 03

ESAB Automation Ltd

Andover
Tel: +44 1264 33 22 33
Fax: +44 1264 33 20 74

HUNGARY

ESAB Kft
Budapest
Tel: +36 1 20 44 182
Fax: +36 1 20 44 186

ITALY

ESAB Saldatura S.p.A.
Mesero (Mi)
Tel: +39 02 97 96 81
Fax: +39 02 97 28 91 81

THE NETHERLANDS

ESAB Nederland B.V.
Utrecht
Tel: +31 30 248 59 22
Fax: +31 30 248 52 60

NORWAY

AS ESAB
Larvik
Tel: +47 33 12 10 00
Fax: +47 33 11 52 03

POLAND

ESAB Sp.z.o.o
Warszaw
Tel: +48 22 813 99 63
Fax: +48 22 813 98 81

PORTUGAL

ESAB Lda
Lisbon
Tel: +351 1 837 1527
Fax: +351 1 859 1277

SLOVAKIA

ESAB Slovakia s.r.o.
Bratislava
Tel: +421 7 44 88 24 26
Fax: +421 7 44 88 87 41

SPAIN

ESAB Ibérica S.A.
Alcobendas (Madrid)
Tel: +34 91 623 11 00
Fax: +34 91 661 51 83

SWEDEN

ESAB Sverige AB
Gothenburg
Tel: +46 31 50 95 00
Fax: +46 31 50 92 22

ESAB International AB

Gothenburg
Tel: +46 31 50 90 00
Fax: +46 31 50 93 60

SWITZERLAND

ESAB AG
Dietikon
Tel: +41 1 741 25 25
Fax: +41 1 740 30 55

North and South America

ARGENTINA

CONARCO
Buenos Aires
Tel: +54 11 4 753 4039
Fax: +54 11 4 753 6313

BRAZIL

ESAB S.A.
Contagem-MG
Tel: +55 31 3369 4333
Fax: +55 31 3369 4440

CANADA

ESAB Group Canada Inc.
Mississauga, Ontario
Tel: +1 905 670 02 20
Fax: +1 905 670 48 79

MEXICO

ESAB Mexico S.A.
Monterrey
Tel: +52 8 350 5959
Fax: +52 8 350 7554

USA

ESAB Welding & Cutting Products
Florence, SC
Tel: +1 843 669 44 11
Fax: +1 843 664 44 58

Asia/Pacific

CHINA

Shanghai ESAB A/P
Shanghai
Tel: +86 21 6539 7124
Fax: +86 21 6543 6622

INDIA

ESAB India Ltd
Calcutta
Tel: +91 33 478 45 17
Fax: +91 33 468 18 80

INDONESIA

P.T. Esabindo Pratama
Jakarta
Tel: +62 21 460 01 88
Fax: +62 21 461 29 29

MALAYSIA

ESAB (Malaysia) Snd Bhd
Selangor
Tel: +60 3 703 36 15
Fax: +60 3 703 35 52

SINGAPORE

ESAB Singapore Pte Ltd
Singapore
Tel: +65 861 43 22
Fax: +65 861 31 95

ESAB Asia/Pacific Pte Ltd

Singapore
Tel: +65 861 74 42
Fax: +65 863 08 39

SOUTH KOREA

ESAB SeAH Corporation
Kyung-Nam
Tel: +82 551 289 81 11
Fax: +82 551 289 88 63

UNITED ARAB EMIRATES

ESAB Middle East
Dubai
Tel: +971 4 338 88 29
Fax: +971 4 338 87 29

Representative offices

BULGARIA

ESAB Representative Office
Sofia
Tel/Fax: +359 2 974 42 88

EGYPT

ESAB Egypt
Dokki-Cairo
Tel: +20 2 390 96 69
Fax: +20 2 393 32 13

ROMANIA

ESAB Representative Office
Bucharest
Tel/Fax: +40 1 322 36 74

RUSSIA-CIS

ESAB Representative Office
Moscow
Tel: +7 095 937 98 20
Fax: +7 095 937 95 80

ESAB Representative Office

St Petersburg
Tel: +7 812 325 43 62
Fax: +7 812 325 66 85

Distributors

For addresses and phone numbers to our distributors in other countries, please visit our home page

www.esab.com



ESAB AB
SE-695 81 LAXÅ
SWEDEN
Phone +46 584 81 000

www.esab.com